

MH-3 Beam

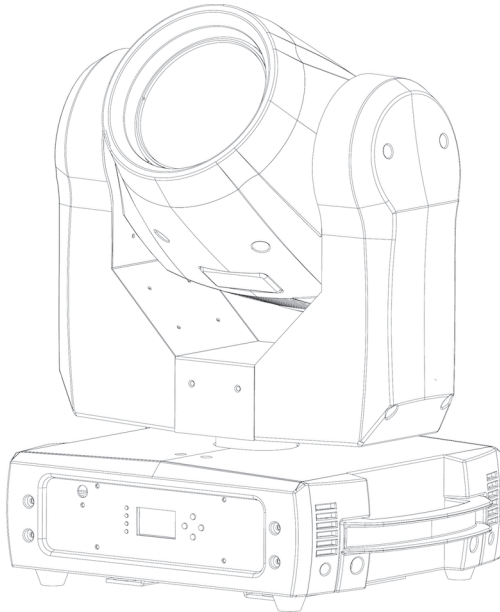

User Manual



Professional Entertainment Technology

© 2013 Martin Professional A/S. Information subject to change without notice. Martin Professional A/S and all affiliated companies disclaim liability for any injury, damage, direct or indirect loss, consequential or economic loss or any other loss occasioned by the use of, inability to use or reliance on the information contained in this manual. The Martin logo, the RUSH by Martin logo, the RUSH by Martin name, the Martin name and all other trademarks in this document pertaining to services or products by Martin Professional A/S or its affiliates and subsidiaries are trademarks owned or licensed by Martin Professional A/S or its affiliates or subsidiaries.

Manual: Revision A

Table of contents

Safety information	5
Introduction	9
Before using the product for the first time	9
Physical installation	10
Fastening the fixture to a flat surface	10
Mounting the fixture on a truss	10
AC power	11
Fixture overview	12
Pan and tilt locks	13
Control data link	14
Tips for reliable data transmission	14
Connecting the data link	14
Fixture setup	15
Using the control menus	16
DMX function settings	16
Fixture settings	17
Lamp settings	18
Display settings	20
Fixture test	21
Fixture information	21
Reset functions or effects	21
Reset factory default settings	22
Effect home position adjustment	22
Effects	23
Lamp control	23
Pan & tilt	23
Dimming	24
Frost filter	24
Zoom	24
Strobe effects	24
Gobos	24
Prism	25
Color wheels	25
Maintenance	25
Changing the lamp	25
Cleaning	28

Service and repairs	29
DMX protocol	30
Control menus.....	35
Offset menu	37
Error messages.....	38
Troubleshooting	39
Specifications	41

Safety information



WARNING!
Read the safety precautions in this manual before installing, powering, operating or servicing this product.

The following symbols are used to identify important safety information on the product and in this manual:



Warning!
Safety hazard. Risk of severe injury or death.



Warning!
Risk of eye injury. Safety glasses must be worn.



Warning!
Refer to manual before installing, powering or servicing.



Warning!
Hazardous voltage. Risk of lethal or severe electric shock.



Warning!
Hot surfaces and fire hazard.



Warning! Risk Group 3 (high risk) product according to EN 62471. Do not view the light output with optical instruments or any device that may concentrate the beam.

This product is for professional use only. It is not for household use. It presents risks of severe injury or death due to fire hazards, electric shock and falls. It produces a powerful, concentrated beam of light that can create a fire hazard or a risk of eye injury if the safety precautions below are not followed.



Read this manual before installing, powering or servicing the fixture, follow the safety precautions listed below and observe all warnings in this manual and printed on the fixture. If you have questions about how to operate the fixture safely, please contact your RUSH by Martin™ dealer or call the Martin 24-hour service hotline at +45 70 200 201.

For the latest user documentation and other information about this and all Martin™ products, please visit the Martin website at <http://www.martin.com>



Protection from electric shock

Shut down power to the fixture before carrying out any installation or maintenance work.

Disconnect the fixture from AC power before removing or installing any cover or part and when not in use.

Ensure that the fixture is electrically connected to ground (earth).

Use only a source of AC power that complies with local building and electrical codes and has both overload and ground-fault (earth-fault) protection.

Replace defective fuses with ones of the specified type and rating only.

Before using the fixture, check that all power distribution equipment and cables are in perfect condition and rated for the current requirements of all connected devices.

Isolate the fixture from power immediately if the power plug or any seal, cover, cable, or other component is damaged, defective, deformed, wet or showing signs of overheating. Do not reapply power until repairs have been completed

Do not expose the fixture to rain or moisture.



Protection from burns and fire

Do not operate the fixture if the ambient temperature (T_a) exceeds 40° C (104° F).

The surface of the product casing can reach up to 85° C (185° F) during operation. Avoid contact by persons and materials. Allow the fixture to cool for at least 10 minutes before handling.

Keep flammable materials well away from the fixture. Keep all combustible materials (e.g. fabric, wood, paper) at least 100 mm (4 in.) away from the fixture head.

Ensure that there is free and unobstructed airflow around the fixture. Provide a minimum clearance of 100 mm (4 in.) around fans and air vents.

Do not illuminate surfaces within 12 m (40 ft.) of the fixture.

Do not attempt to bypass thermostatic switches or fuses.

Do not stick filters, masks or other materials onto any optical component.



Lamp safety

Install only a lamp that is approved for use in the product.

Prolonged exposure to an unshielded discharge lamp can cause eye and skin burns. Do not stare directly into the light output. Never look at an exposed lamp while it is lit.

Do not operate the fixture with missing or damaged covers, shields, lenses or ultraviolet screens.



A hot discharge lamp is under pressure and can explode without warning. Allow the fixture to cool for at least 2 hours and protect yourself with safety glasses and gloves before handling a lamp.

Replace the lamp immediately if it becomes visually deformed, damaged or in any way defective.

Monitor hours of lamp use and lamp intensity and replace the lamp when it reaches the limit of its service life as specified in this manual or by the lamp manufacturer.

If the quartz envelope of a discharge lamp is broken, the lamp releases a small quantity of mercury and other toxic gases. If a discharge lamp explodes in a confined area, evacuate the area and ventilate it thoroughly. Wear nitrile gloves when handling a broken discharge lamp. Treat broken or used discharge lamps as hazardous waste and send to a specialist for disposal.



Protection from injury

Do not look directly into the light beam. Do not point the beam in a direction where a person can look directly into it. Ensure that persons are not looking at the light beam when the product lights up suddenly. This can happen when power is applied, when the product receives a DMX signal, or when certain control menu items are selected.

Do not look at the beam with magnifiers, telescopes, binoculars or similar optical instruments that may concentrate the light output.

To minimize the risk of eye irritation or injury, disconnect the fixture from power at all times when the fixture is not in use, and provide well-lit conditions to reduce the pupil diameter of anyone working on or near the fixture.



Fasten the fixture securely to a fixed surface or structure when in use. The fixture is not portable when installed.

Ensure that any supporting structure and/or hardware used can hold at least 10 times the weight of all the devices they support.

If suspending from a rigging structure, fasten the fixture to a rigging clamp. Do not use safety cables as the primary means of support.

If the fixture is installed in a location where it may cause injury or damage if it falls, install a secondary attachment such as a safety cable that is approved by an official body such as TÜV as a safety attachment for the weight that it secures. The safety cable must comply with EN 60598-2-17 Section 17.6.6 and be capable of bearing a static suspended load that is ten times the weight of the fixture and all installed accessories.

Allow enough clearance around the head to ensure that it cannot collide with an object or another fixture when it moves.

Check that all external covers and rigging hardware are securely fastened.

Block access below the work area and work from a stable platform whenever installing, servicing or moving the fixture.

Do not operate the fixture with missing or damaged covers, shields or any optical component.

Do not lift or carry the fixture by its head. Always ensure that the fixture is supported by its base.

In the event of an operating problem, stop using the fixture immediately and disconnect it from power. Never attempt to use a fixture that is obviously damaged.

Do not modify the fixture or install other than genuine RUSH by Martin™ parts. Refer any service operation not described in this manual to a qualified technician.

Introduction

The MH-3 Beam is a high performance moving head, equipped with an MSD Platinum 5R lamp in a state-of-the-art optical system that incorporates a 1°~3.8° zoom. Its compact design makes it ideal for live shows, TV events, stage and concerts.

The fixture provides a rotating gobo wheel with 17 fixed indexable gobos, a color wheel with 14 indexable color filters, smooth mechanical dimming, pan/tilt feedback, coarse and fine control of movement and effects, a range of built-in movement and effects macros, prism effects, electrical focus, as well as frost and strobe effects. The device is extremely rugged, lightweight and compact, and is ideal for touring applications or small fixed installations.

The onboard battery enables the setting of fixture characteristics such as the DMX address, without connecting to mains power.

The fixture can be controlled using any DMX-compliant controller.

The fixture is supplied with this user manual, a 1.5 m (5 ft) power cable (local power plug not included) and two mounting brackets.

Before using the product for the first time

1. Read Safety information on page 5 before installing, powering, operating or servicing the fixture.
2. Unpack and ensure that there is no transportation damage before using the fixture. Never attempt to operate a damaged fixture.
3. If the fixture is not going to be hard-wired to a mains supply, attach a local power plug (not supplied) to the end of the supplied power cable.
4. Before operating, ensure that the voltage and frequency of the power supply match the power requirements of the fixture.
5. Check the Martin Professional website at www.martin.com for the most recent user documentation and technical information about the fixture. RUSH by Martin user manual revisions are identified by the revision letter at the bottom of the inside cover.

Note that whenever AC power is applied to the fixture, it will reset all effects and functions to their home positions. The fixture head will move. This process usually takes around 20 seconds.

Unlock the pan and tilt locks on the head yoke before applying power.

Physical installation

The fixture is designed for indoor use only and must be used in a dry location with adequate ventilation. Always ensure that none of the fixture's ventilation slots are blocked and always ensure that the product is firmly affixed to avoid vibration during operation.

Fastening the fixture to a flat surface

The fixture can be fastened to a hard fixed flat surface that is oriented at any angle. Ensure that the surface can support at least 10 times the weight of all fixtures and equipment to be installed on it.

Fasten the fixture securely. Do not stand it on a surface or leave it where it can be moved or fall over. Attach a securely anchored safety cable to the fixture if it is installed in any location where it may fall and cause injury or damage if the primary attachment fails.

Mounting the fixture on a truss

The fixture can be clamped to a truss or similar rigging structure in any orientation. When clamping a fixture to a truss:

1. Check that the rigging structure can support at least 10 times the weight of all fixtures and equipment to be installed on it.
2. Block access under the work area.
3. The fixture is supplied with two brackets to which clamps can be attached. Attach these brackets to the base of the fixture and secure using the quarter-turn screws.
4. Rig the fixture using clamps and hardware suitable for the purpose, such as omega clamps. Working from a stable platform, hang the fixture on the truss. Tighten the rigging clamps and hardware.
5. Secure the fixture against clamp failure with a secondary attachment such as an approved safety cable that is rated for the weight of the fixture.
6. Check that the head will not collide with other fixtures or objects.

AC power



Read Safety information on page 5 before connecting the fixture to AC mains power.



For protection from electric shock, the fixture must be grounded (earthed). The power distribution circuit must be equipped with a fuse or circuit breaker and ground-fault (earth-fault) protection.

Socket outlets or external power switches used to supply the fixture with power must be located near the fixture and easily accessible so that the fixtures can easily be disconnected from power.

Do not insert or remove live Neutrik PowerCon connectors to apply or cut power, as this may cause arcing at the terminals that will damage the connectors.

Do not use an external dimming system to supply power to the fixture, as this may cause damage to the fixture that is not covered by the product warranty.

Always unlock the pan and tilt locks on the head yoke before turning the fixture on.

Connect only a Neutrik PowerCon cable connector to the power input socket.

The power input cable must be rated 20 A minimum, have three conductors 1.5 mm² (16 AWG) minimum conductor size and an outer cable diameter of 5 - 15 mm (0.2 - 0.6 in.). Cable must be hard usage type (SJT or equivalent) and heat-resistant to 90° C (194° F) minimum. In the EU the cable must be HAR approved or equivalent.

The fixture can be hard-wired to a building electrical installation if you want to install it permanently, or a mains plug (not supplied) that is suitable for the local power outlets can be installed on the power cable.

The fixture has an auto-ranging power supply that accepts AC mains power at 100V~240V, 50/60 Hz. Do not apply AC mains power to the fixture at any other voltage than this.

Fixture overview

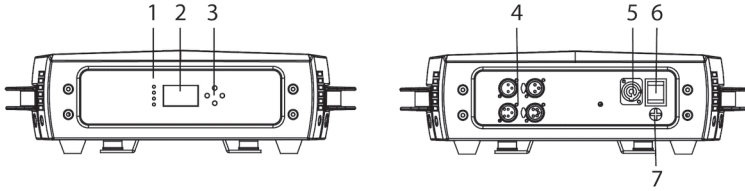

1 - LEDs

The fixture has three LEDs on the front of the base:

Power	Power on
Battery	Battery in use
DMX	DMX signal present

2 – Display

3 – Buttons

MENU	<ul style="list-style-type: none">• Activate the menu mode functions, or• Return to the previous level of the menu structure, or• Hold to exit the menus
DOWN	Go down a menu branch
UP	Go up a menu branch
ENTER	Confirm the selected function

Hold and press the MENU button to exit the menu mode.

4 - DMX XLR input/output sockets

3 and 5-pin XLR sockets are provided for the DMX input and output (throughput).

5 – AC mains power input

A blue Neutrik PowerCon socket is provided to connect the fixture to mains power.

6 – Power on/off switch

7 – Fuse

The T5A fixture fuse is located under the cover below the power switch.

Pan and tilt locks

Always disengage the pan (yaw) and tilt locks before turning on the fixture.

The discharge lamp used in the fixture is very delicate, so engage the pan and tilt and yaw locks before moving or transporting the fixture.

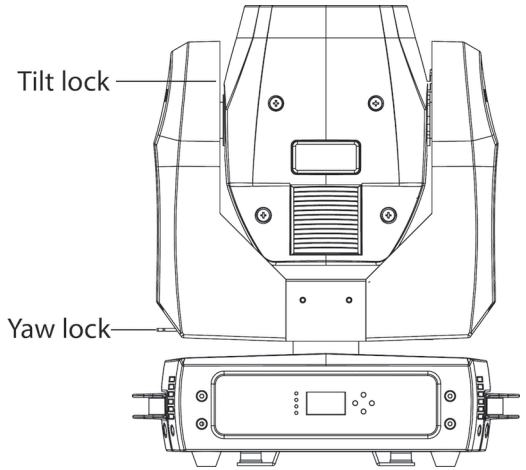

Control data link

A DMX 512 data link is required in order to control the fixture via DMX. The fixture has 3-pin and 5-pin XLR connectors for DMX data input and output.

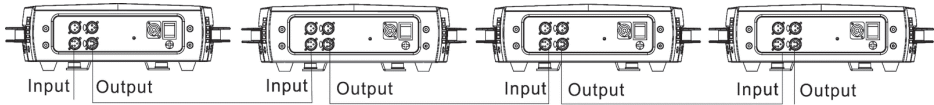

The number of daisy-chained fixtures is limited by the number of DMX channels required by the fixtures in relation to the maximum 512 channels available in one DMX universe. Note that if independent control of a fixture is required, it must have its own DMX channels. Fixtures that are required to behave identically can share the same DMX address and channels. To add more fixtures or groups of fixtures when the above limit is reached, add a DMX universe and another daisy-chained link.

Tips for reliable data transmission

Use shielded twisted-pair cable designed for RS-485 devices: standard microphone cable cannot transmit control data reliably over long runs. 24 AWG cable is suitable for runs up to 300 meters (1000 ft.). Heavier gauge cable and/or an amplifier is recommended for longer runs. The pin-out on all connectors is pin 1 = shield, pin 2 = cold (-), and pin 3 = hot (+). Pins 4 and 5 in the 5-pin XLR connectors are not used in the fixture but are available for possible additional data signals as required by the DMX512-A standard. Standard pin-out is pin 4 = data 2 cold (-) and pin 5 = data 2 hot (+).

To split the link into branches, use a splitter, such as the Martin 4-Channel Opto-Isolated RS-485 Splitter/Amplifier. Terminate the link by installing a termination plug in the output socket of the last fixture. The termination plug, which is a male XLR plug with a 120 Ohm, 0.25-Watt resistor soldered between pins 2 and 3, “soaks up” the control signal so it does not reflect and cause interference. If a splitter is used, terminate each branch of the link.

Connecting the data link

To connect the fixture to data:

1. Connect the DMX data output from the controller to the closest fixture's male XLR DMX input connector.
2. Connect the DMX output of the fixture closest to the controller to the DMX input of the next fixture and continue connecting fixtures output to input. Terminate the last fixture on the link.

Fixture setup

This section explains the fixture characteristics that can be set that determine how it can be controlled and will behave. These settings are made using the menus available from the control panel, and are retained, even when the fixture is powered off.

A complete map of the control menu structure and brief explanations of their purposes can be found in

Control menus on page 35.

The onboard battery enables the setting of fixture characteristics without connecting to mains power.

Using the control menus

To access the control menus, press the MENU button. Navigate the menu structure using the ENTER, DOWN and UP buttons. Select any required menu option using the ENTER button. To return to a higher level in the menu structure without any change press the MENU button.

To exit the menus, press and hold the MENU button.

DMX function settings

DMX function settings include the DMX address and DMX mode. Note that if a fixture loses its DMX signal it will maintain its current effect until powered off or reset.

DMX addressing

The fixture can be controlled using signals sent by a DMX controller over 19 DMX channels. The DMX address, also known as the start channel, is the first channel used to receive instructions from a DMX controller. Each DMX controlled fixture must have a DMX address set. If a fixture has its DMX address set to 11, then it uses channels 11 to 29. The following fixture in the DMX chain could then be set to a DMX address of 30.

For independent control, each fixture must be assigned its own control channels. Two fixtures of the same type may share the same address, if identical behavior is desired. Address sharing can be useful for diagnostic purposes and symmetric control, particularly when combined with the inverse pan and tilt options.

The DMX address is configured using the DMX FUNCTIONS menu in the control panel.

To set the fixture's DMX address:

1. Select DMX FUNCTIONS and press the ENTER button
2. Use the UP and DOWN buttons to select DMX ADDRESS and press the ENTER button to confirm. The present address will blink on the display.
3. Use the UP and DOWN buttons to select the address (1 to 512).
4. Once the address has been selected, press the ENTER button to set it. To return to the higher level of the menu structure without any change press the MENU button again.

Fixture settings

Pan and/or tilt inversion

The FIXTURE SETTINGS→PAN INVERSE and TILT INVERSE menus can be used to reverse the direction of pan and/or tilt. These settings are useful for symmetrical effects with multiple fixtures, or when coordinating the movement of fixtures that are floor mounted and rigged upside down.

To adjust the pan inversion settings:

1. Select FIXTURE SETTINGS and press the ENTER button to confirm.
2. Use the DOWN and UP buttons to select PAN INVERSE or TILT INVERSE and press the ENTER button to confirm.
3. Use the DOWN and UP buttons to select the YES (inversion) or NO (normal) mode.
4. Press the ENTER button to confirm (or, to return to the higher level of the menu structure without any change press the MENU button).

Pan/tilt feedback

When pan/tilt feedback is enabled and a pan or tilt position error is detected, the fixture will correct the pan/tilt position.

To deactivate, or activate this function use the FIXTURE SETTINGS→P/T FEEDBACK menu.

Blackout during change or movement

The fixture can be set, so that when running a show, blackout is enabled during gobo change, color change, and/or pan and tilt movement. This is switched off by default. To adjust the blackout during show playback settings:

1. Select FIXTURE SETTINGS and press the ENTER button to confirm.
2. Use the DOWN and UP buttons to select BL. O. P/T MOVING, BL. O. COLOR CHANGE, or BL. O: GOBO CHANGE and press the ENTER

button to confirm.

3. Use the DOWN and UP buttons to select the YES (blackout during movement or change) or NO (normal) mode.
4. Press the ENTER button to confirm (or, to return to the higher level of the menu structure without any change press the MENU button).

Lamp settings

Lamp on/off

To turn the lamp on or off:

1. Select LAMP SETTINGS and press the ENTER button to confirm.
2. Use the DOWN and UP buttons to select ON/OFF and press the ENTER button to confirm.
3. Use the DOWN and UP buttons to select ON or OFF.
4. Press the ENTER button to confirm (or, to return to the higher level of the menu structure without any change press the MENU button).

State/power on

To set the state of the lamp when the fixture is powered on:

1. Select LAMP SETTINGS and press the ENTER button to confirm.
2. Use the DOWN and UP buttons to select STATE/POWER ON and press the ENTER button to confirm.
3. Use the DOWN and UP buttons to select ON or OFF.
4. Press the ENTER button to confirm (or, to return to the higher level of the menu structure without any change press the MENU button).

Off via DMX

To enable the lamp to be turned off via DMX:

1. Select LAMP SETTINGS and press the ENTER button to confirm.
2. Use the DOWN and UP buttons to select OFF VIA DMX and press the ENTER button to confirm.
3. Use the DOWN and UP buttons to select NO or YES.
4. Press the ENTER button to confirm (or, to return to the higher level of the menu structure without any change press the MENU button).

On if DMX on

To enable or disable the lamp being turned on automatically if a DMX signal is present:

1. Select LAMP SETTINGS and press the ENTER button to confirm.
2. Use the DOWN and UP buttons to select ON IF DMX ON and press the ENTER button to confirm.
3. Use the DOWN and UP buttons to select NO or YES.
4. Press the ENTER button to confirm (or, to return to the higher level of the menu structure without any change press the MENU button).

Off if DMX off

To enable or disable the lamp being turned off automatically if a DMX signal is not present:

1. Select LAMP SETTINGS and press the ENTER button to confirm.
2. Use the DOWN and UP buttons to select OFF IF DMX OFF and press the ENTER button to confirm.
3. Use the DOWN and UP buttons to select NO or YES.
4. Press the ENTER button to confirm (or, to return to the higher level of the menu structure without any change press the MENU button).

Ignition delay

An ignition delay of 0 to 255 seconds can be set, so that there is a delay between power on and lamp on:

1. Select LAMP SETTINGS and press the ENTER button to confirm.
2. Use the DOWN and UP buttons to select IGNITION DELAY and press the ENTER button to confirm.
3. Use the DOWN and UP buttons to specify a duration.
4. Press the ENTER button to confirm (or, to return to the higher level of the menu structure without any change press the MENU button).

Low power delay

A low power delay is where the lamp runs at half power for a period before shutting off when a lamp off command is issued:

1. Select LAMP SETTINGS and press the ENTER button to confirm.
2. Use the DOWN and UP buttons to select LOW POWER DELAY and press the ENTER button to confirm.

3. Use the DOWN and UP buttons to specify a duration.
4. Press the ENTER button to confirm (or, to return to the higher level of the menu structure without any change press the MENU button).

Display settings

Invert display

Inverting the display is useful if the fixture is hung from a truss or from elevation. To invert the display:

1. Select DISPLAY SETTINGS and press the ENTER button to confirm.
2. Use the DOWN and UP buttons to select DISPLAY INVERSE and press the ENTER button to confirm.
3. Use the DOWN and UP buttons to select the YES (invert).
4. Press the ENTER button to confirm (or, to return to the higher level of the menu structure without any change press the MENU button).

Automatically turn off display backlight

By default the display is lit when the power is applied to the fixture. It can be set to automatically dim if the buttons and menus have not been used for a period:

1. Select DISPLAY SETTINGS and press the ENTER button to confirm.
2. Use the DOWN and UP buttons to select BACKLIGHT AUTO OFF and press the ENTER button to confirm.
3. Use the DOWN and UP buttons to select the YES.
4. Press the ENTER button to confirm (or, to return to the higher level of the menu structure without any change press the MENU button).

Adjust backlight intensity

The brightness of the control panel display can be adjusted:

1. Select DISPLAY SETTINGS and press the ENTER button to confirm.
2. Use the DOWN and UP buttons to select BACKLIGHT INTENSITY and press the ENTER button to confirm.
3. Use the DOWN and UP buttons to set a level from 1 to 10.
4. Press the ENTER button to confirm (or, to return to the higher level of the menu structure without any change press the MENU button).

Fixture test

Automatic tests of all functions, or manual test of individual functions can be run from the control menus.

Auto test

To perform a complete test of all of the fixture functions:

1. Select FIXTURE TEST and press the ENTER button to confirm.
2. Use the DOWN and UP buttons to select AUTO TEST and press the ENTER button to confirm. The automatic test will run.

Manual test

Fixture functions can be tested or controlled manually:

1. Select FIXTURE TEST and press the ENTER button to confirm.
2. Use the DOWN and UP buttons to select MANUAL TEST and press the ENTER button to confirm.
3. To return to a higher level of the menu press the MENU button again.

Fixture information

Fixture operating hours counter

To see how many hours the fixture has been used:

1. Select FIXTURE INFORMATION and press the ENTER button to confirm.
2. Use the DOWN and UP buttons to select FIXTURE USE TIME and press the ENTER button to confirm. The number of hours will be shown.

Lamp operating hours counter

This counter can be reset, so it can be used to monitor when a lamp change is required. The counter is available under the FIXTURE INFORMATION→LAMP ON TIME menu.

Firmware version

To see what software version is installed in the fixture:

3. Select FIXTURE INFORMATION and press the ENTER button to confirm.
4. Use the DOWN and UP buttons to select FIRMWARE VERSION and press the ENTER button to confirm. The firmware version will be shown.

Reset functions or effects

The various effects—pan, tilt color, gobos, iris, focus, prism—or all effects, can

be manually reset to their home positions:

1. Select RESET FUNCTIONS and press the ENTER button to confirm.
2. Use the DOWN and UP buttons to select the function or effect that is to be reset. Press the ENTER button.
3. Use the DOWN and UP buttons to select YES and press the ENTER button to confirm (or to return to a higher level of the menu structure without any change press the MENU button).

Reset factory default settings

The fixture's default settings can be restored using SPECIAL FUNCTIONS→FACTORY SETTINGS.

Effect home position adjustment

The various effects— pan, tilt, shutter, color, gobo, prism, rotating prism, zoom, focus and frost—can lose or move out of their indexed home position. To reset any of these:

1. In the menu structure, hold the ENTER button down for at least 3 seconds to enter the OFFSET MENU.
2. Use the DOWN and UP buttons to choose the function that needs to be adjusted. Press the ENTER button to select it.
3. The present indexed home position will appear blinking in the display. Use the DOWN and UP buttons to adjust the home position of the function or effect.
4. Once the correct position has been reached, press the ENTER button to set this (or to return to a higher level of the menu structure without any change press the MENU button).

Effects

This section describes DMX-controllable effects that require particular explanation. See DMX protocol on page 30 for a full list of the DMX channels and values required to control the different effects.

Lamp control

The fixture can be set up to turn the lamp on or off depending on whether or not a DMX signal is present. The fixture can also be setup to enable lamp off commands via DMX control.

An ignition delay of 0 to 255 seconds can be set, so that there is a delay between power on and lamp on.

A low power delay can also be defined where the lamp runs at half power for a period before shutting off when a lamp off command is issued.

For more information, see Lamp settings on page 18.

Pan & tilt

The fixture's moving head can be panned through 540° and tilted through 270° using coarse or fine control channels. The fixture can be set to automatically blackout during pan and tilt movement. A range of pan/tilt macros is available.

The fixture incorporates pan and tilt feedback, so that if a pan or tilt position error is detected, the shutter closes and the fixture resets to the correct position. This can be enabled or disabled as required (see

Control menus on page 35).

Dimming

Full range mechanical dimming is provided. Two dimming curves are available—linear or conventional—and either of these can be selected using the function channel.

Frost filter

A frost filter is provided.

Zoom

The fixture provides a 1°~ 3.8° zoom.

Strobe effects

A range of variable speed and random shutter/strobe effects are provided.

Gobos

The fixture contains a rotating wheel with 17 fixed gobos:

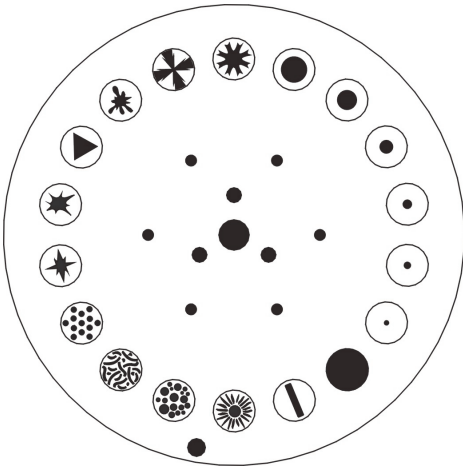

Gobo1



Gobo2



Gobo3



Gobo4



Gobo5



Gobo6



Gobo7



Gobo8



Gobo9



Gobo10



Gobo11



Gobo12



Gobo13



Gobo14



Gobo15



Gobo16



Gobo17



White

Any gobo can be projected statically, or the wheel can be rotated, both clockwise and counter-clockwise at variable speeds. The fixture can be set to

automatically blackout during gobo changes. The sharpness of gobo projections can be adjusted using the electronic focus.

Prism

The fixture incorporates an 8-faceted prism that can be inserted into the beam to provide split effects. The prism can be set to an indexed position or rotated clockwise or counter-clockwise. A range of prism macros and movement effects are provided.

Color wheels

The fixture incorporates a single color wheel, with 14 color filters (plus open). These colors can be individually selected, split colors are available and the wheel can be rotated at varying speeds, both clockwise and counter-clockwise. The fixture can be set to automatically blackout during color changes.

Maintenance



Warning! Read Safety information on page 5 before maintaining the fixture. Always comply with the safety instructions.

Refer any service operation not described in this user manual to a qualified service technician.

Always disconnect mains power before cleaning or servicing the fixture.

Fixtures must be serviced in an area where there is no risk of anyone being injured by failing parts, tools or other materials.

Excessive dust, smoke fluid, and particle buildup degrades performance, causes overheating and will damage the fixture. Damage caused by inadequate cleaning or maintenance is not covered by the product warranty.

Changing the lamp



Warning! Wear safety glasses and gloves when handling lamps.



To avoid the risk of a discharge lamp exploding in the fixture, always replace the lamp before its expected lifespan has been exceeded.

The lamp must be perfectly clean. Never touch the lamp with bare hands. If this happens, clean the lamp with an alcohol wipe and dry it with a lint-free cloth.

To replace the lamp:

1. Ensure that the fixture is detached from power and has cooled down completely. It is a good idea to allow the fixture to run for 10 minutes after the lamp has been turned off, so that the cooling fans have time to work.
2. Remove the fixture head covers using a Phillips screwdriver.

3. Remove the fan at the rear of the head.

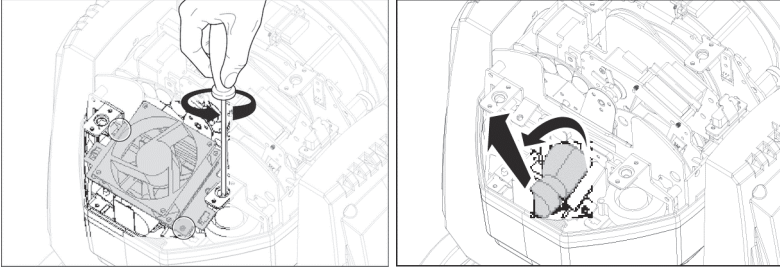

4. Lift the lamp out of its recess.
5. Disconnect the lamp and connect the replacement lamp. Only use approved lamp.

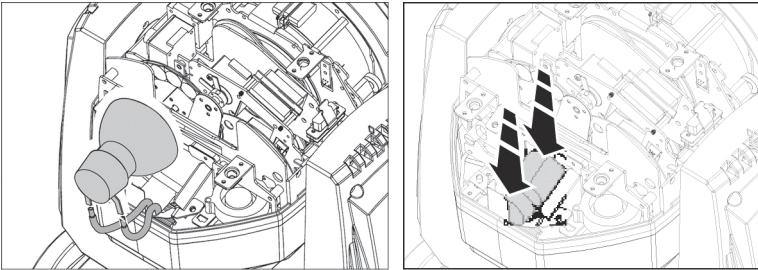

6. Place the new lamp into the lamp recess.
7. The lamp can be adjusted using a slotted (flat head) screwdriver. Ensure that the lamp is located in the center of the reflector for the best projection.

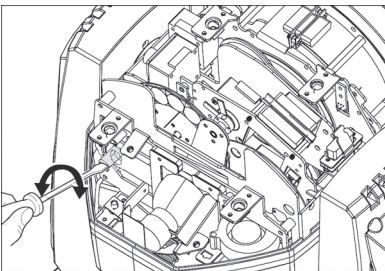

8. Replace the fan and secure it.
9. Replace and secure the head covers.
10. Remember to reset the lamp hour counter using the control panel.

For maximum lamp operating life:

- Avoid powering the lamp off until it has warmed up for at least 5 minutes.
- Before shutting down power completely, douse the lamp but leave power applied for a few minutes so that cooling fans can prevent any momentary lamp temperature increase caused by heat from surrounding components.

Cleaning

The cleaning of external optical lenses must be carried out periodically to optimize light output. Cleaning schedules for lighting fixtures vary greatly depending on the operating environment. It is therefore impossible to specify precise cleaning intervals for the fixture. Environmental factors that may result in a need for frequent cleaning include:

- Use of smoke or fog machines.
- High airflow rates (near air conditioning vents, for example).
- Presence of cigarette smoke.
- Airborne dust (from stage effects, building structures and fittings or the natural environment at outdoor events, for example).

If one or more of these factors is present, inspect fixtures within their first 100 hours of operation to see whether cleaning is necessary. Check again at frequent intervals. This procedure will allow you to assess cleaning requirements in your particular situation. If in doubt, consult your RUSH by Martin dealer about a suitable maintenance schedule.

Use gentle pressure only when cleaning, and work in a clean, well-lit area. Do not use any product that contains solvents or abrasives, as these can cause surface damage.

To clean the fixture:

1. Disconnect the fixture from power and allow it to cool for at least 10 minutes.
2. Vacuum or gently blow away dust and loose particles from the outside of the fixture and the air vents at the back and sides of the head and in the base with low-pressure compressed air.
3. Clean the LED lenses by wiping gently with a soft, clean lint-free cloth moistened with a weak detergent solution. Do not rub the surface hard: lift particles off with a soft repeated press. Dry with a soft, clean, lint-free cloth or low-pressure compressed air. Remove stuck particles with an unscented tissue or cotton swab moistened with glass cleaner or distilled water.

4. Check that the fixture is dry before reapplying power.

Service and repairs

There are no user serviceable parts inside the fixture. Do not open the housing.

Never try to repair the fixture by yourself as this may result in damage, malfunction and it may potentially void your product warranty. The equipment must only be serviced or repaired by an authorized RUSH by Martin service technician.

Installation, on-site service and maintenance can be provided worldwide by the Martin Professional Global Service organization and its approved agents, giving owners access to Martin's expertise and product knowledge in a partnership that will ensure the highest level of performance throughout the product's lifetime. Please contact your RUSH by Martin supplier for details.

DMX protocol

Channel	Value	Function
1	1-255	Pan 0°~540°
2	1-255	Pan (fine control)
3	1-255	Tilt 0°~270°
4	1-255	Tilt (fine control)
5	1-255	Pan/tilt speed – fast-slow
6	Function	
	0-29	No function
	30-39	Dimmer conventional mode
	40-49	Dimmer linear mode
	50-59	Pan/tilt fast mode
	60-69	Pan/tilt normal mode
	70-79	Blackout during pan & tilt
	80-89	Disable blackout during pan & tilt
	90-99	Blackout during color change
	100-109	Disable blackout during color change
	110-119	Blackout during gobo change
	120-129	Disable blackout during gobo change
	130-139	Lamp on
	140-149	Pan/tilt reset
	150-159	Color reset
	160-169	Gobo reset
	170-179	Shutter/prism/rotating prism reset
	180-189	No function
	190-199	Frost/focus/zoom reset
	200-209	Reset all
210-219	Blackout during pan/tilt or color/gobo change	
220-229	Disable blackout during pan/tilt or color/gobo change	
230-239	Lamp off	
240-255	No function	
7	Pan/tilt macros	
	0-7	Off
	8-15	Macro 1
	16-23	Macro 2
	24-31	Macro 3
	32-39	Macro 4
	40-47	Macro 5

Channel	Value	Function
	48-55	Macro 6
	56-63	Macro 7
	64-71	Macro 8
	72-79	Macro 9
	80-87	Macro 10
	88-95	Macro 11
	96-103	Macro 12
	104-111	Macro 13
	112-119	Macro 14
	120-127	Macro 15
	128-135	Macro 16
	136-143	Macro 17
	144-151	Macro 18
	152-159	Macro 19
	160-167	Macro 20
	168-175	Macro 21
	176-183	Macro 22
	184-191	Macro 23
	192-199	Macro 24
	200-207	Macro 25
	208-215	Macro 26
216-223	Macro 27	
224-231	Macro 28	
232-239	Macro 29	
240-247	Macro 30	
248-255	Macro 31	
8	1-255	Pan/tilt macro speed – fast-slow
9	Color	
	0-2	Open
	3-4	Split color
	5-6	Red
	7-8	Split color
	9-10	Yellow
	11-12	Split color
	13-14	Blue
	15-16	Split color
	17-18	Blue Green
	19-21	Split color
	22-23	Green
	24-25	Split color
	26-27	Light blue
	28-29	Split color

Channel	Value	Function
	30-31	Light pink
	32-33	Split color
	34-35	Yellow green
	36-37	Split color
	38-39	Dark pink
	40-42	Split color
	43-44	Blue
	45-46	Split color
	47-48	Light yellow
	49-50	Split color
	51-52	Off white
	53-54	Split color
	55-56	Light blue
	57-58	Split color
	59-60	Dark blue
	61-63	Split color (with open)
	64-127	Color wheel indexing
	128-189	Clockwise rotation – fast-slow
	190-193	Stop
	194-255	Counter-clockwise rotation – slow-fast
10	Gobos	
	0-3	Open
	4-6	Gobo 1
	7-9	Gobo 2
	10-12	Gobo 3
	13-15	Gobo 4
	16-18	Gobo 5
	19-21	Gobo 6
	22-24	Gobo 7
	25-27	Gobo 8
	28-30	Gobo 9
	31-33	Gobo 10
	34-36	Gobo 11
	37-39	Gobo 12
	40-42	Gobo 13
	43-45	Gobo 14
	46-48	Gobo 15
	49-51	Gobo 16
	52-55	Gobo 17
	56-59	Open gobo shake
	60-63	Gobo 1 shake

Channel	Value	Function
	64-67	Gobo 2 shake
	68-71	Gobo 3 shake
	72-75	Gobo 4 shake
	76-79	Gobo 5 shake
	80-83	Gobo 6 shake
	84-87	Gobo 7 shake
	88-91	Gobo 8 shake
	92-95	Gobo 9 shake
	96-99	Gobo 10 shake
	100-103	Gobo 11 shake
	104-107	Gobo 12 shake
	108-111	Gobo 13 shake
	112-115	Gobo 14 shake
	116-119	Gobo 15 shake
	120-123	Gobo 16 shake
	124-127	Gobo 17 shake
	128-189	Wheel rotation, counter-clockwise, fast-slow
	190-193	Stop
	194-255	Wheel rotation, clockwise, slow-fast
11	Prism	
	0-7	No function
	8-127	Prism effect
	128-132	Prism rotation effects 1
	133-137	Prism rotation effects 2
	138-141	Prism rotation effects 3
	142-146	Prism rotation effects 4
	147-150	Prism rotation effects 5
	151-155	Prism rotation effects 6
	156-159	Prism rotation effects 7
	160-164	Prism rotation effects 8
	165-168	Prism rotation effects 9
	169-173	Prism rotation effects 10
	174-177	Prism rotation effects 11
	178-182	Prism rotation effects 12
	183-187	Prism rotation effects 13
	188-191	Prism rotation effects 14
	192-196	Prism rotation effects 15
	197-200	Prism rotation effects 16
201-205	Prism rotation effects 17	
206-209	Prism rotation effects 18	
210-214	Prism rotation effects 19	

Channel	Value	Function
	215-218	Prism rotation effects 20
	219-223	Prism rotation effects 21
	224-227	Prism rotation effects 22
	228-232	Prism rotation effects 23
	233-236	Prism rotation effects 24
	237-241	Prism rotation effects 25
	242-246	Prism rotation effects 26
	247-250	Prism rotation effects 27
	251-255	Prism rotation effects 28
12		Prism rotation (coarse control)
	0-127	Indexing
	128-189	Prism rotation, clockwise, fast-slow
	190-193	Stop
	194-255	Prism rotation, counter-clockwise, slow-fast
13	1-255	Prism rotation (fine control)
14	1-255	Prism movement effect
15	1-255	Focus – near-far
16	1-255	Frost – 0-100%
17		Shutter
	0-7	Off
	8-15	Open
	16-131	Shutter strobe effect, slow-fast
	132-167	Fast close, slow open
	168-203	Slow close, fast open
	204-239	Pulse open and close
	240-247	Random shutter
	248-255	Open
18	1-255	Dimmer (coarse control) – 0-100%
19	1-255	Dimmer (fine control)

Control menus

To access the control menus, press the MENU button. Use the UP and DOWN buttons to navigate the menus. Select any required menu option using the ENTER button. For more information, see Using the control menus on page 16.

Default fixture settings are shown in **bold**.

Menu	Sub-menu	Setting/value	Explanation
DMX Functions	DMX Address	1–493	Fixture DMX address setting
	View DMX Value		View received DMX values
Fixture setting	Pan Inverse	No	
		Yes	
	Tilt Inverse	No	
		Yes	
	P/T Feedback	No	If a pan or tilt position error is detected, the fixture corrects pan/tilt position
		Yes	
	Bl.O. P/T Moving	No	Blackout during pan/tilt movement
		Yes	
	Bl.O. Color Change	No	Blackout during color change
		Yes	
Bl.O. Gobo Change	No	Blackout during gobo change	
	Yes		
Lamp Setting	On/Off	Off	
		On	
	State/Power On	Off	
		On	
	Off via DMX	No	
		Yes	
	On if DMX On	No	
		Yes	
	Off if DMX Off	No	
		Yes	
Ignition Delay	0~255S	Delay lamp ignition: 0 to 255 seconds.	
Low Power Delay	0~255S	Low power delay: 0 to 255 seconds.	
Display	Display inverse	No	Invert control panel

Menu	Sub-menu	Setting/value	Explanation
settings		Yes	display
	Backlight Auto Off	No	Automatically turn off display panel backlight when not in use.
		Yes	
	Backlight Intensity	1-10	Display panel backlight intensity
	Temperature Unit	°C	Temperature display: Celsius/Fahrenheit
		°F	
Display Warning	No		
	Yes		
Fixture Test	Auto Test		Automatic test of all functions
	Manual Test		
Fixture Information	Fixture Use Time		Fixture operating hour counter
	Lamp On Time	Exit	
		Reset Time	Reset lamp hour use counter
Firmware Version		Current installed firmware version	
Reset Functions	Pan/Tilt	No	
		Yes	
	Shutter/Dimmer	No	
		Yes	
	Color	No	
		Yes	
	Gobo	No	
		Yes	
	Zoom/Frost/Focus	No	
		Yes	
	All	No	
		Yes	
Special Functions	Fixture Maintenance	Interval	
		Remain time	
	Factory Settings	No	
		Yes	

Offset menu

The offset menu is used to adjust the home position of the various effects.

To access the Offset menu, press the MENU button to enter the menu structure and then press and hold the ENTER button for three seconds.

Menu	Sub-menu	Setting	Explanation
Offset Menu	Pan	-128~127	Pan offset
	Tilt	-128~127	Tilt offset
	Shutter	0~255	Shutter offset
	Color	-128~127	Color offset
	Gobo	-128~127	Gobo offset
	Prism	0~255	Prism offset
	R-Prism	-128~127	Rotating prism offset
	Zoom	0~255	Zoom offset
	Focus	0~255	Focus offset
	Frost	0~255	Frost offset

Error messages

Error:	Appears when:
Lamp Startup Fail	No lamp or some wires are damaged.
Temperature Sense Error	Temperature sensor on the PCB is damaged.
Lamp Too Hot Power Off	Temperature is detected higher than 110° C. Ensure that the fixture is adequately ventilated. The fans or temperature sensor might be damaged (contact Martin support).
Lamp Too Hot Low Power	Temperature is detected higher than 105° C. The fixture runs at a low power level.
Maintenance Fixture	Fixture maintenance is required (based on the countdown timer). Maintain the fixture, and then reset the countdown timer using the menus.
Lamp On Over 700 Hour	The fixture has been on for more than 700 hours. Turn the fixture off.
Memory Initial Fail	Damaged memory IC (contact Martin support).
CPU-B Error, CPU-C Error, CPU-D Error	Board P.C or fixture wiring is damaged (contact Martin support).
Pan Reset Error Pan Encode Error Tilt Reset Error Tilt Encode Error Shutter Reset Fail Dimmer Reset Fail Color Reset Fail Gobo Reset Fail Frost Reset Fail	These can appear when powering on or resetting the fixture and can indicate damage to sensors or components (contact Martin support).

Troubleshooting

This section describes a few common problems that may occur during operation and provides some suggestions for easy troubleshooting:

Symptom	Potential cause	Remedies
No light from fixture, or fans not working.	Power supply issue, such as blown fuse, faulty connector or damaged cable.	<p>Ensure that the mains supply is connected and supplying power to the fixture.</p> <p>Ensure that the fixture's power-on LED is lit.</p> <p>Check all power connections and cables.</p> <p>Replace the fixture fuse.</p>
One of the control channels is unresponsive or only responds intermittently.	Damaged step motor or cable connection between the head and body.	Contact your RUSH by Martin authorized distributor or service center for assistance.
Lamp cuts out intermittently	Incorrect mains voltage or the internal temperature is too high.	<p>Check mains voltage.</p> <p>Fan may need replacing. Contact your RUSH by Martin™ authorized distributor or service center for assistance.</p>

Symptom	Potential cause	Remedies
<p>Fixture does not respond to DMX control.</p>	<p>Fault in the DMX network due to connector or cable damaged, or incorrect DMX addressing, or potential interference from proximity to a high voltage installation.</p>	<p>Check that the fixture DMX LED is on, and if not, check all DMX cables and connections to ensure the integrity of the physical network.</p> <p>Ensure that the DMX network is terminated.</p> <p>Check that the components in the DMX network all use standard DMX polarity.</p> <p>Ensure that the fixture is set to the DMX address that matches the address set on the DMX control device.</p> <p>Check the pins on the connectors from the previous fixture in the DMX network.</p> <p>Attempt to control the fixture with another DMX control device.</p> <p>Move the fixture if it is being operated very close to an unshielded high-voltage installation.</p>

Specifications

Physical

Weight..... 20.5 kg (45.2 lbs.)
 Dimensions (W x H x D) 418 x 489 x 321 mm (16.5 x 19.3 x 12.6 in.)

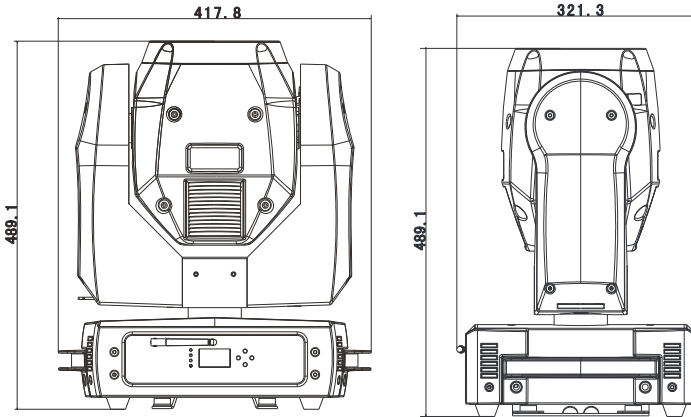

Lamp

Approved lamp..... Philips MSD Platinum 5R
 Color temperature..... 8000 K
 CRI (Color rendering index)..... 75
 Average lifetime..... 2000 hours

Dynamic Effects

Color wheel.... 14 colors plus open, rotation with variable direction and speed
 Static gobo wheel 17 gobos plus open, wheel rotation and shake

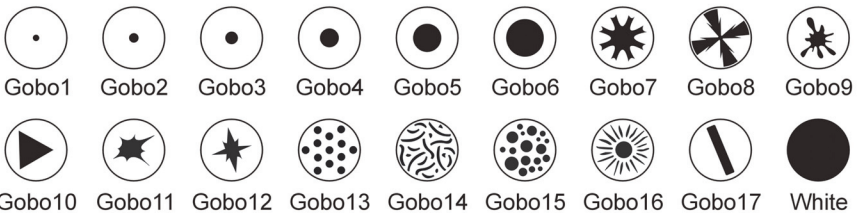

Pre-programmed effects 31 pan and tilt macros, adjustable speed
 Shutter Strobe effect, pulse effects, instant open and blackout
 Prism..... 8-facet, indexing and rotation with variable direction and speed
 Frost..... Fade in/out

Zoom Motorized
 Focus Motorized
 Dimmer..... 0 - 100%, four dimming curve options
 Pan.....540°, with coarse & fine control and speed, P/T macros
 Tilt270°, with coarse & fine control and speed, P/T macros

Optics

Beam angle 1° - 3.8°

Control and Programming

Control options DMX
 DMX channels..... 19
 Setting and addressing Control panel with backlit LCD display
 DMX compliance USITT DMX512/1990
 Pan and tilt speed Adjustable via onboard control panel and DMX
 Head position Pan/tilt feedback correction

Construction

Color..... Black
 IP rating.....IP 20

Installation

Location..... Indoor use only, must be fastened to surface or structure
 Mounting points..... Two quarter-turn brackets for rigging clamps
 Orientation..... Any

Connections

AC power input Neutrik PowerCon
 DMX data in/out 3-pin & 5-pin locking XLR

Electrical

AC power 100-240 V, 50/60Hz
 Fuse T5A
 Power supply unit.....Auto-ranging electronic switch mode

Typical power and current

110 V, 60 Hz 334 W, 3.2 A
 230 V, 50 Hz 312 W, 1.6 A

Thermal

Cooling Forced air
 Maximum ambient temperature (T_a max.) 40° C (104° F)
 Minimum ambient temperature (T_a min) 0° C (32° F)

Included Items

Power cable, 1.5 m, without mains plug

Specifications are subject to change without notice. For latest product specifications, see www.martin.com



Disposing of this product

RUSH by Martin™ products are supplied in compliance with Directive 2002/96/EC of the European Parliament and of the Council of the European Union on WEEE (Waste Electrical and Electronic Equipment), as amended by Directive 2003/108/EC, where applicable. Help preserve the environment! Ensure that this product is recycled at the end of its life. Your supplier can give details of local arrangements for the disposal of RUSH by Martin products



Innovation • Quality • Performance